

Data sheet

MULTICAL® 62

- Ultrasonic water meter
- Pinpoint measuring accuracy
- No wear and long lifetime
- Complete range of communication modules
- Up to 13 years' battery lifetime

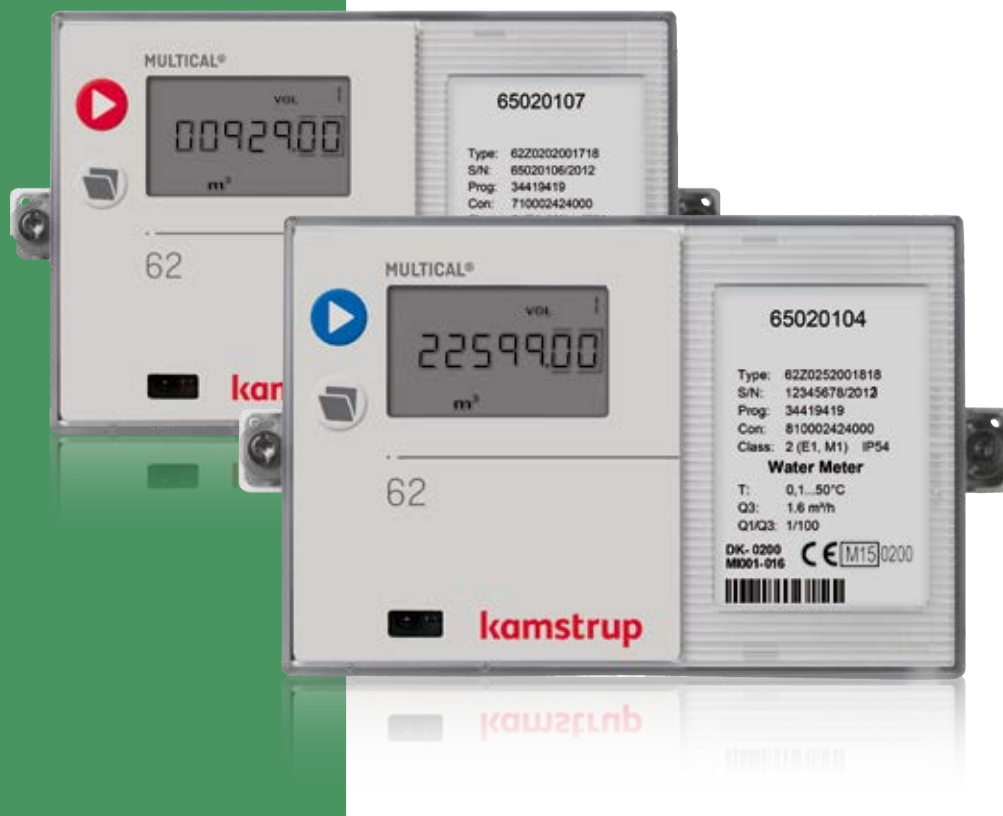

Contents

Application	3
Approved meter data	4
Technical data	4
Accuracy	6
Materials	7
Ordering details	8
ULTRAFLOW® 24 flow meter types	9
Accessories	10
Leak surveillance	11
Programming	11
Dimensioned sketches	11
Pressure loss	14
Straight inlet	15
Installation example	16

Application

Pinpoint accuracy

MULTICAL® 62 is an ultrasonic water meter, which is used for measurement of cold water consumption (0.1...50 °C) and hot water consumption (0.1...90 °C) in trade, industry and housing.

The ultrasonic meter does not include any mechanical parts, which means that it is not subject to wear. This prolongs the meter's lifetime considerably, and even at low flows the water meter maintains its pinpoint accuracy throughout its entire lifetime.

Communication possibilities

MULTICAL® 62 is characterized by its large range of communication modules and integral RTC (Real Time Clock), which makes it easy to fit the meter into all applications independent of reading type. The meter can be fitted with LON, SIOX, M-Bus, a data module and the solutions BACnet MS/TP, Metasys N2, ModBus RTU and Ethernet/IP for wired communication.

If the meter is to be integrated in a wireless network, you can select radio, Wireless M-Bus, Zigbee or options like GSM/GPRS, 3G GSM/GPRS or High-Power RadioRouter with High-Power supply.

Leak surveillance

The meter registers leakages and unintended water consumption due to running cisterns and leaky heating spirals in tap water tanks. In this way the consumer becomes aware of untightnesses which must be repaired in order to avoid too high water consumption, resulting in costly water bills.

In case of power failure, there is made a back-up, thus preventing loss of consumption data.

Longevity

Furthermore, MULTICAL® 62 has a low internal power consumption and up to 13 years' battery lifetime. The unique combination of pinpoint measuring accuracy and the meter's longevity, secures minimal yearly operating costs. Alternatively the meter can be mains supplied, either by 24 VAC or 230 VAC.

General description

MULTICAL® 62 is a static water meter based on the ultrasonic principle and microprocessor technique. The water meter is based on our experience since 1991 with the development and production of static ultrasonic meters. All circuits for calculation of flow metering are placed in the calculator base part. The flow part does not contain any electronics in order to avoid condensation.

The meter has been subjected to a very comprehensive OIML R49 type test with a view to securing a long-term stable, accurate and reliable meter. One of the water meter's many advantages is the fact that it has no wearing parts, which prolongs its lifetime considerably. Furthermore, the meter has a low starting flow (from only 3 l/h), providing accurate measurement also at low flows.

MULTICAL® 62 can be fitted with plug-in modules in both calculator top (top modules) and in connecting base (base modules). Thus, the meter can be adapted to many different applications and data readings.

In addition to the water meter's own data, MULTICAL® 62 has two extra pulse inputs, VA and VB, for collection and remote accumulation of pulses from e.g. water meters and electricity meters. The pulse inputs are placed in the base modules. Pulse inputs VA and VB function independently of the other inputs/outputs.

All registers are saved daily in an EEPROM for 460 days. Furthermore, monthly data for the latest three years and yearly data for the latest 15 years are saved. These can be read out via METERTOOL HCW.

Other reading options are: Operating hour counter, current flow, max. and min. flow, information code, customer number and segment test etc. – depending on configuration.

Characteristics - in short:

- electronic ultrasonic meter
- accurate and reliable
- no moving parts – no wear
- low start flow
- several communication modules
- set/Reset via front buttons
- back-up of data at power down/power failure
- high resolution volume for test
- large clear display
- multiple info codes
- hourly logger
- long-term stable
- High Power supply modules (24 VAC and 230 VAC)

Approved meter data

MID classifications

Approval	DK-0200-MI001-016
Standard	OIML R49 WELMEC guide 8.11
EU-directives	MID (Measuring Instrument Directive) LVD (Low Voltage Directive) EMC (Electromagnetic Compatibility Directive) PED (Pressure Equipment Directive) Category 1 (DN50 – DN80)
Mechanical environment	Class M1
Electromagnetic environment	Class E1
Climatic class	5...55 °C, non-condensing, closed location (indoor installation)

OIML R49 type designation

Accuracy class	2
Environmental class	Fulfils OIML R49 class B
Temperature of medium in flow part	
– Cold water meter	0.1...50 °C (or 0.1...30 °C)
– Hot water meter	0.1...90 °C
Flow meter part	ULTRAFLOW® 24

Drinking water approvals

DVGW W 421, WRAS

Technical data

Electrical data

Supply voltage	3.6 V ± 0.1 VDC
Battery	3.65 VDC, D-cell lithium
Replacement interval	
– Mounted on wall	12+1 years @ tBAT < 30 °C
– Mounted on flow part	10 years @ tBAT < 40 °C
	The replacement interval is reduced by using data modules, frequent data communication and high ambient temperature.
Power supply	230 VAC +15/-30 %, 50/60 Hz 24 VAC ± 50 %, 50/60 Hz
Power consumption mains supply	< 1 W
Backup mains supply	Integral super-cap eliminates interruptions due to short-term power-cuts (only supply modules of types 602-0000-7 and 602-0000-8).
EMC data	Fulfils OIML R49 class E1

Technical data

Pulse inputs VA and VB VA: 65-66 and VB: 67-68	Water meter connection FF(VA) and GG(VB) = 01-40	Electricity meter connection FF(VA) and GG(VB) = 50-60
Pulse input	680 kΩ pull-up to 3.6 V	680 kΩ pull-up to 3.6 V
Pulse ON	< 0.4 V for > 0.1 sec.	< 0.4 V for > 0.1 sec.
Pulse OFF	> 2.5 V for > 0.1 sec.	> 2.5 V for > 0.1 sec.
Pulse frequency	< 1 Hz	< 3 Hz
Electrical isolation	No	No
Max. cable length	25 m	25 m

Pulse outputs CE and CV – via top module 67-08	
Type	Open collector (OB)
Pulse length	Optionally 32 msec. or 100 msec.
External voltage	5-30 VDC
Current	1-10 mA
Residual voltage	$U_{CE} \approx 1 \text{ V}$ at 10 mA
Electrical isolation	2 kV
Max. cable length	25 m

Mechanical data

Metrological class	2
Environmental class	Fulfils OIML R49 class B
Mechanical environment	MID class M1
Electromagnetic environmental class	Fulfils OIML R49 class E1
Ambient temperature	5...55 °C, non-condensing, closed location (indoor installation)
Protection class	Calculator IP54 Flow part IP68
Temperature of medium	
– Cold water meter	0.1...30 °C (T30)
– Cold water meter	0.1...50 °C (T50)
– Hot water meter	0.1...90 °C (T90)
Storage temperature	-25...60 °C (drained flow part)
Weight	0.4 kgs excl. flow part
Pressure stage	
– Thread mounted meter	PN16
– Flange mounted meter	PN25
Flow meter cable	2.5 m

Accuracy

MPE according to OIML R49

Meter approved T50 (0.1...50 °C) and T90 (0.1...90 °C)

MPE (maximum permissible error)

For $0.1\text{ °C} < t \leq 30\text{ °C}$

$\pm 5\%$ in range $Q_1 \leq Q < Q_2$

$\pm 2\%$ in range $Q_2 \leq Q \leq Q_4$

For $30\text{ °C} < t \leq 90\text{ °C}$

$\pm 3\%$ in range $Q_2 \leq Q \leq Q_4$

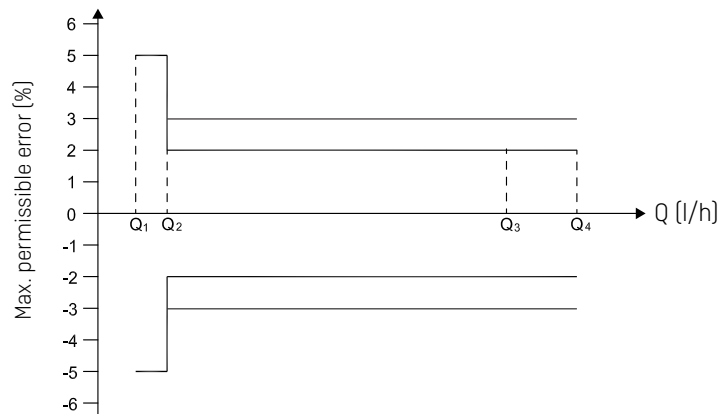

Q₁: Minimum Flowrate

The lowest flowrate at which the water meter provides indications that satisfy the requirements concerning the maximum permissible errors (MPEs.).

Q₂: Transitional Flowrate

The transitional flowrate is the flowrate value occurring between the permanent and minimum flowrates, at which the flowrate range is divided into two zones, the 'upper zone' and the 'lower zone'. Each zone has a characteristic MPE.

Q₃: Permanent Flowrate

The highest flowrate at which the water meter operates in a satisfactory manner under normal conditions of use, i.e. under steady or intermittent flow conditions.

Q₄: Overload Flowrate

The overload flowrate is the highest flowrate at which the meter operates in a satisfactory manner for a short period of time without deteriorating.

Materials

Wetted parts

Meter housing, coupling	DZR brass (dezincification brass CW511L)
Meter housing, flange	Stainless steel W.no. 1.4408
Transducer	Stainless steel W.no. 1.4401
Gaskets	EPDM
Measuring tube	Thermoplastic, PES 30 % GF
Reflectors, mirrors	Stainless steel 1.4305, 1.4306, 1.4401

Signal house

Base	Thermoplastic, PBT 30 % GF
Cover	Thermoplastic, PC 20 % GF
Wall bracket	Thermoplastic, PC 20 % GF

Calculator house

Top	Thermoplastic, PC
Base	Thermoplastic, ABS with TPE gaskets (thermoplastic elastomer)
Internal cover	Thermoplastic, ABS

Flow part cable

Copper cable with silicone jacket and inner Teflon insulation

Ordering details

MULTICAL® 62	Type 62-Z			00			
Top module							
No module	0						
Data output + hourly data logger	5						
M-Bus	7						
RTC + 2 pulse outputs for CE and CV + prog. data logger	B						
2 Pulse outputs CE and CV	C						
Base module							
No module		00					
Data + pulse inputs		10					
M-Bus + pulse inputs		20					
RadioRouter + pulse inputs		21					
Prog. data logger + RTC + 4...20 mA inputs + pulse inputs		22					
0/4...20 mA outputs		23					
LonWorks + pulse inputs		24					
Radio + pulse inputs (internal antenna) 434 or 444 MHz		25					
Radio + pulse inputs (external antenna connection) 434 or 444 MHz		26					
M-Bus module with medium data package + pulse inputs		28					
M-Bus module with MC-III data package + pulse inputs		29					
Wireless M-Bus Mode C1 + pulse inputs		30					
Wireless M-Bus, Mode T1 OMS 15 min. (ind. key)		31					
Wireless M-Bus, Mode C1 Fixed Network (ind. key)		38					
ZigBee 2.4 GHz int.ant. + pulse inputs		60					
Metasys N2 (RS485) + pulse inputs		62					
SIOX module (Auto detect Baud rate)		64					
BACnet MS/TP + pulse input		66					
Modbus RTU + pulse inputs		67					
GSM/GPRS module (GSM6H)		80					
3G GSM/GPRS module (GSM8H)	Require High Power supply modules	81					
Ethernet/IP module (IP201)		82					
High Power RadioRouter + 2 pulse inputs		84					
Supply							
No supply				0			
Battery, D-cell				2			
230 VAC high power isolated SMPS				3			
24 VAC high power isolated SMPS				4			
230 VAC isolated linear supply				7			
24 VAC isolated linear supply				8			
Flow part							
Supplied with one ULTRAFLOW® 24						1	
Meter type							
Hot water meter							7
Cold water meter							8
Country code (language on label etc.)							XX

ULTRAFLOW® 24 flow meter types

Type number	Nom. Q ₃ m ³ /h	Max. Flow Q ₄ [m ³ /h]	Min. Flow Q ₁ [l/h]	Min. cutoff [l/h]	Pressure loss Δp @ Q ₃ [bar]	Connection on meter	Length [mm]	Anti-pollu- tion check valve ¹⁾	Strainer ¹⁾
65-2-CDAA-XXX	1.6	2.0	16	3	0.25	G¾B (R¾)	110	-	-
65-2 -CDA1-XXX	1.6	2.0	16	3	0.25	G1B (R¾)	110	-	-
65-2-CDAC-XXX ^{**)}	1.6	2.0	16	3	0.25	G¾B (R¾)	165	OK	OK
65-2-CDAF-XXX	1.6	2.0	16	3	0.25	G1B (R¾)	190	OK	OK
65-2-CEAF-XXX	2.5	3.1	25	6	0.04	G1B (R¾)	190	OK	OK
65-2-CGAG-XXX	4.0	5.0	40	7	0.09	G1¼B (R1)	260	OK	OK
65-2-CHAG-XXX	6.3	7.9	63	12	0.22	G1¼B (R1)	260	OK	OK
65-2-CJAJ-XXX	10	12.5	100	20	0.06	G2B (R1½)	300	OK	OK
65-2-CKCE-XXX	16	20	160	30	0.16	DN50	270	-	-
65-2-CLCG-XXX	25	31.3	250	50	0.06	DN65	300	-	-
65-2-CMCH-XXX	40	50	400	80	0.05	DN80	300	-	-

* Anti-pollution check valve and strainer are only valid options for cold water meter, max. 50 °C.

** MULTICAL® 62 with flow part type 65-2-CDAC (G¾B x 165) is only available as cold water meter.

Max. pressure loss according to OIML R49 between Q₁ up to and incl. Q₃ must not exceed 0.063 MPa (0.63 bar), at Q₄ max. 0.1 MPa (1 bar).

The type number of the flow part cannot be changed after factory programming.

The delivery code can also be used for:

- language and approval on type label
- marking of PN class

Customer labels (2001-XXX) are integrated in the front label.

Accessories

Couplings, incl. gaskets

6561-326	Gland incl. gasket for DN15, (R½ x G¾), [2 pcs.]
6561-327	Gland incl. gasket for DN20, (R¾ x G1), [2 pcs.]
6561-328	Gland incl. gasket for DN25, (R1 x G5/4), [1 pc.]
6561-329	Gland incl. gasket for DN40, (R1½ x G2), [1 pc.]

Gaskets (AFM 34 for cold and hot water)

Gasket for coupling:		Gasket for flange:	
3130-251	G¾ (R½) [2 pcs.]	3130-131	DN50 [2 pc.]
3130-252	G1 (R¾) [2 pcs.]	2210-141	DN65 [1 pc.]
3130-253	G1¼ (R1) [2 pcs.]	2210-140	DN80 [1 pc.]
3130-254	G2 (R1½) [2 pcs.]		

Strainer for flow part inlet *)

6556-513	Strainer DN15 for G¾B (R½) [1 pc.], not for 110 mm housing
6556-514	Strainer DN20 for G1B (R¾) [1 pc.]
6556-509	Strainer DN25 for G1¼B (R1) [1 pc.]
6556-510	Strainer DN40 for G2B (R1½) [1 pc.]

Anti-pollution check valve (EN 13959) for flow part return, incl. PE gasket (PE = Polyethylene) *)

6556-480	Anti-pollution check valve DN15 for G¾B, incl. strainer and 2 PE gaskets, not for 110 mm housing
6556-481	Anti-pollution check valve DN20 for G1B, incl. strainer and 2 PE gaskets
6556-482	Anti-pollution check valve DN25 for G5/4B, incl. PE gasket
6556-483	Anti-pollution check valve DN40 for G2B, incl. PE gasket

PE gasket for strainer and anti-pollution check valve *)

6556-494	DN15 [10 pcs.]
6556-495	DN20 [10 pcs.]

Pulse Transmitter (Cable extension set)

6699-618.0	Pulse Transmitter without cable
6699-618.2	Pulse Transmitter incl. 10 m cable

* Back-flow protection, strainer (filter) and PE-gaskets must only be used in cold water meters.

Leak surveillance

MULTICAL® 62 can monitor the water consumption. Possible running cisterns, leaky heating spirals of tap water tanks or other untightnesses can result in water flow being registered from the water meter 24 hours a day.

If MULTICAL® 62 does not register e.g. at least one continuous hour/day without water flow from the water meter, this implies a leakage in the water system and an alarm will be sent via remote communication.

When the meter has registered a leak, an alarm message can be sent to a receiving station, where incoming alarms are processed according to an encoded action pattern determined for each customer, e.g. starting with an SMS message to the customer's mobile phone parallel with the water station on guard receiving the message. Regular data readings from MULTICAL® 62 to receiving station/control centre ensure that defective remote readings, if any, are detected.

Programming

MULTICAL® 62 can be ordered in combinations as required by the customer.

The supplied meter is configured from the factory and ready for use, but can also be changed/reconfigured after installation.

However, this does not apply to the meter's legal parameters (type number and CCC-code) which cannot be changed unless the verification seal is broken. This requires that changes must be made in an accredited meter laboratory.

The CCC-code states the calculator's adaption to a specific flow part type to the effect that calculating speed and display resolution are optimized for the selected flow part at the same time as type approval regulations about minimum resolution and maximum register overflow are obeyed.

Dimensioned sketches

MULTICAL® 62

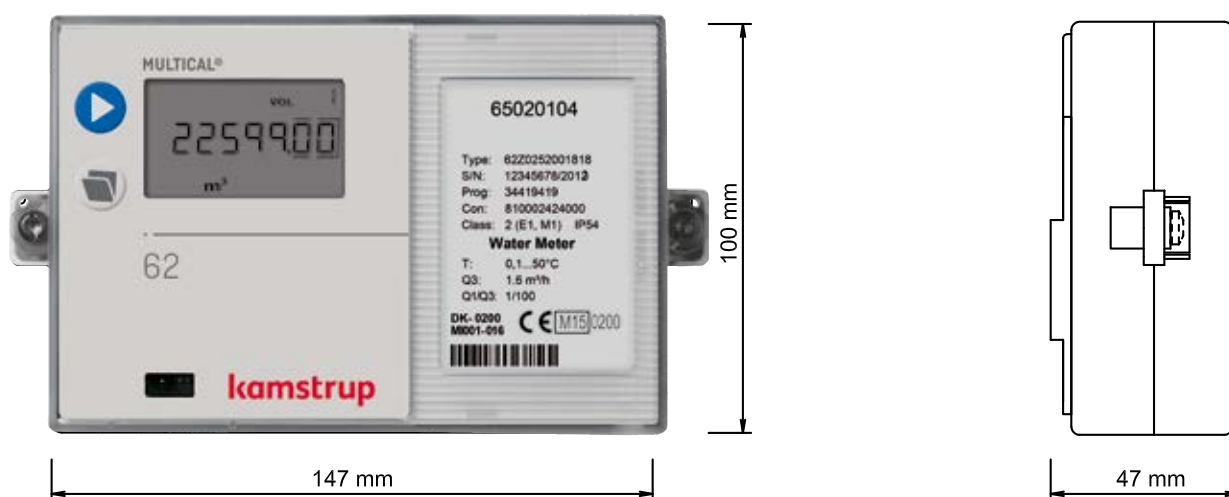

Dimensioned sketches

ULTRAFLOW® 24, G $\frac{3}{4}$ B and G1B

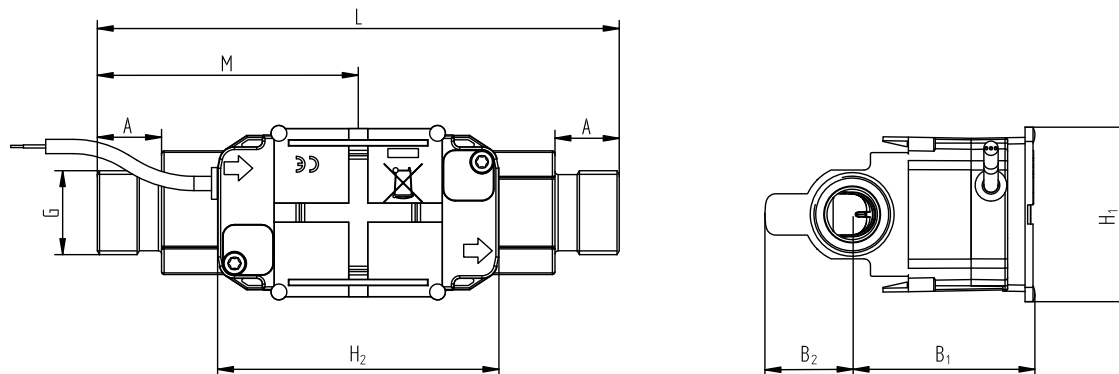

Thread ISO 228-1	L [mm]	M [mm]	H ₂ [mm]	A [mm]	B ₁ [mm]	B ₂ [mm]	H ₁ [mm]	App. weight [kg]
G $\frac{3}{4}$ B (Q ₃ =1.6 m ³ /h)	110	L/2	89	10.5	58	36	55	0.8
G $\frac{3}{4}$ B (Q ₃ =1.6 m ³ /h)	165	L/2	89	20.5	58	29	55	1.2
G1B (Q ₃ =1.6 m ³ /h)	110	L/2	89	10.5	58	28	55	0.9
G1B (Q ₃ =1.6 m ³ /h)	190	L/2	89	20.5	58	29	55	1.4
G1B (Q ₃ =2.5 m ³ /h)	190	L/2	89	20.5	58	29	55	1.3

ULTRAFLOW® 24, G1 $\frac{1}{4}$ B and G2B

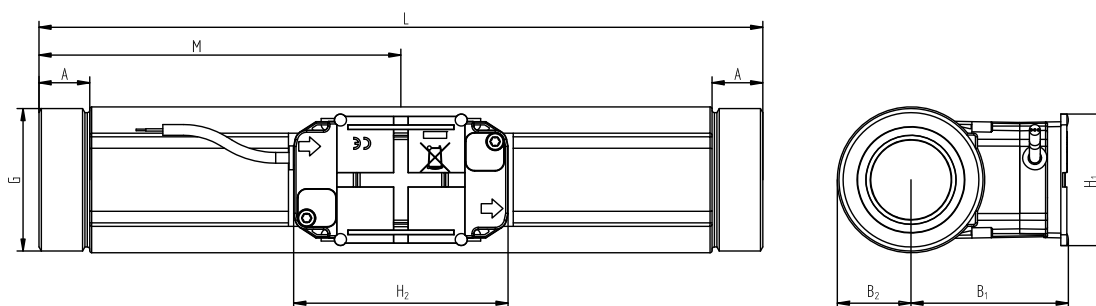

Thread ISO 228-1	L [mm]	M [mm]	H ₂ [mm]	A [mm]	B ₁ [mm]	B ₂ [mm]	H ₁ [mm]	App. weight [kg]
G1 $\frac{1}{4}$ B (Q ₃ =4 & 6.3 m ³ /h)	260	L/2	89	17	58	22	55	2.3
G2B (Q ₃ =10 m ³ /h)	300	L/2	89	21	65	31	55	4.5

Dimensioned sketches

ULTRAFLOW® 24, DN50

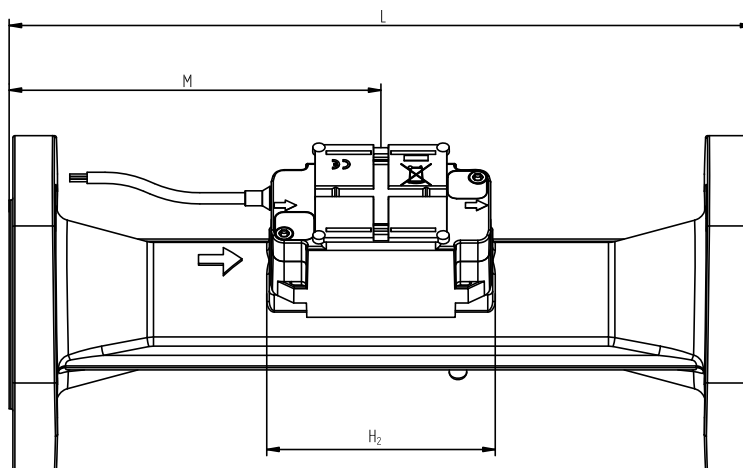

Flange EN 1092, PN25

Nom. dia.	L [mm]	M [mm]	H ₂ [mm]	B ₁ [mm]	D [mm]	H [mm]	k [mm]	Bolts			App. weight [kg]
								No.	Thread	d ₂	
DN50 (Q ₃ =16 m ³ /h)	270	155	89	65	165	145	125	4	M16	18	10.1

ULTRAFLOW® 24, DN65 and DN80

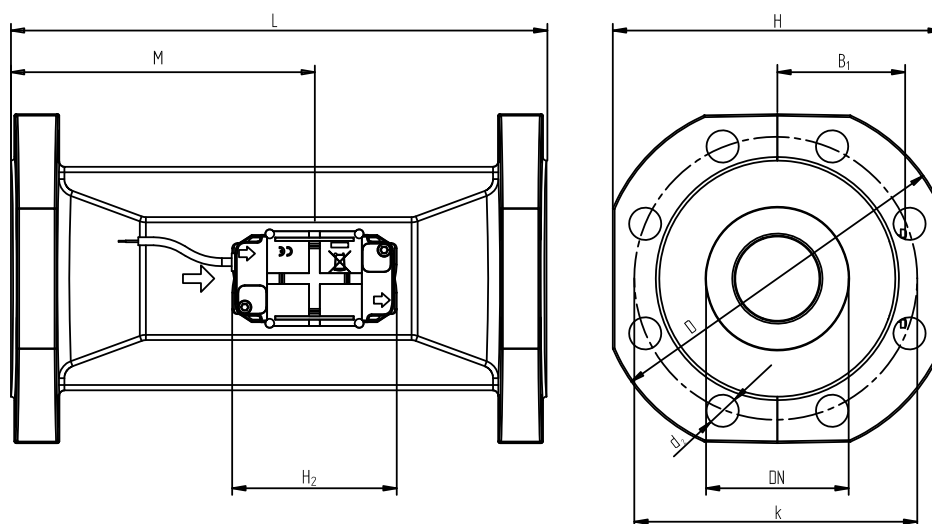

Flange EN 1092, PN25

Nom. dia.	L [mm]	M [mm]	H ₂ [mm]	B ₁ [mm]	D [mm]	H [mm]	k [mm]	Bolts			App. weight [kg]
								No.	Thread	d ₂	
DN65 (Q ₃ =25 m ³ /h)	300	170	89	72	185	168	145	8	M16	18	13.2
DN80 (Q ₃ =40 m ³ /h)	300	170	89	80	200	184	160	8	M16	18	16.8

Pressure loss

According to OIML R49 the maximum pressure loss must not exceed 0.63 bar in range Q_1 up to and incl. Q_3 , or max. 1.0 bar at Q_4 respectively. The pressure loss is without anti-pollution check valve.

The pressure loss in a flow part increases with the square of the flow and can be stated as:

$$Q = k_v \times \sqrt{\Delta p}$$

where

Q = volume flow rate [m^3/h]

k_v = volume flow rate at 1 bar pressure loss [m^3/h]

Δp = pressure loss [bar]

Graph	Q_3 [m^3/h]	Nom. diameter [mm]	k_v	$Q @ 0.63 \text{ bar}$ [m^3/h]
A	1.6	DN15 & DN20	3.2	2.5
B	2.5 & 4 & 6.3	DN20 & DN25	13.4	10.6
C	10 & 16	DN40 & DN50	40	32
D	25	DN65	102	81
E	40	DN80	179	142

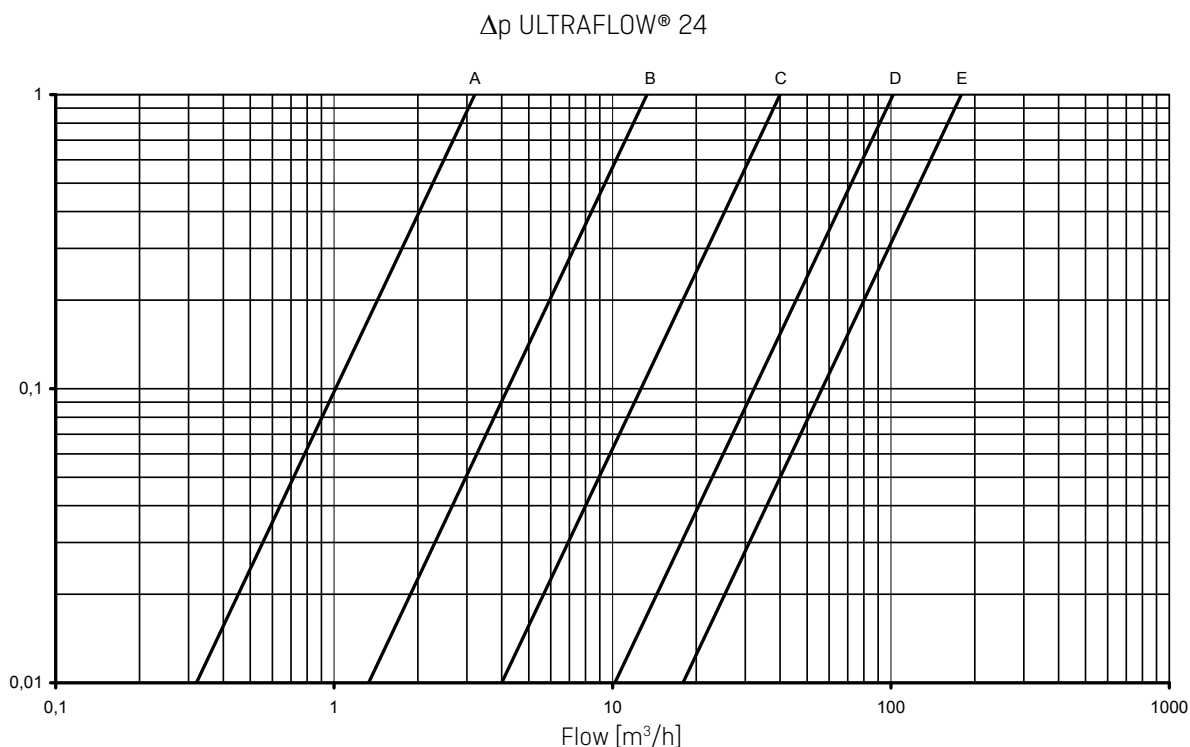

Installation angle for ULTRAFLOW® 24

ULTRAFLOW® 24 can be mounted vertically, horizontally or at an angle.

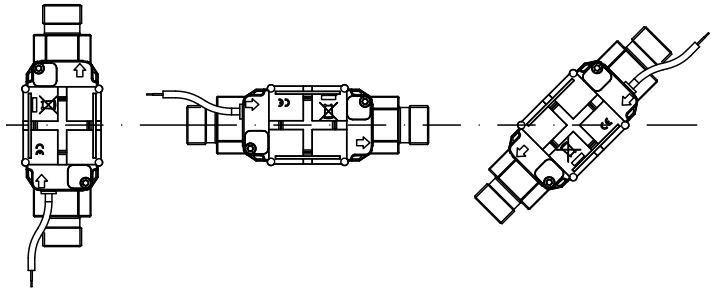

Important!

ULTRAFLOW® 24 can be turned upward to $\pm 45^\circ$ and down to $\pm 90^\circ$ in relation to the pipe axis.

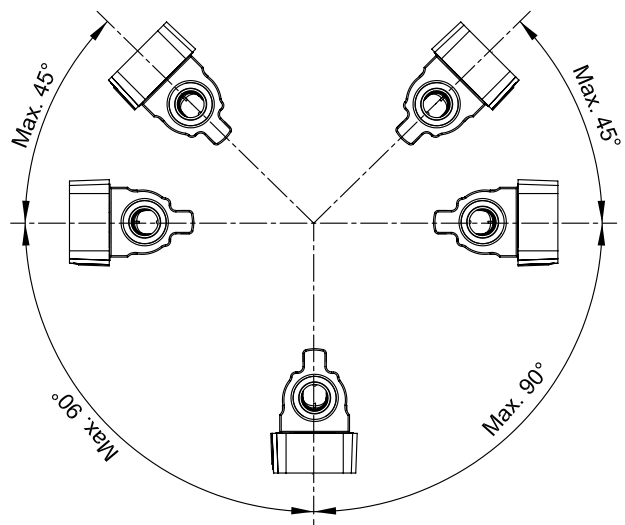

The plastic housing must not be mounted vertically upward, due to risk of air build-up in the system.

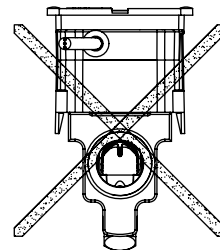

Straight inlet

ULTRAFLOW® requires neither straight inlet nor outlet to meet the Measuring Instruments Directive (MID) 2004/22/EC and OIML R49:2006. Only in case of heavy flow disturbances before the meter will a straight inlet section be necessary.

Installation example

In order to avoid condensation in the calculator it must not be mounted direct on the flow part.

If the calculator must be mounted on the flow part, the angle fitting 3026-252, which is shown in the figure below to the right, or the socket extender 65-61-332 shown at the bottom of this page, must be used.

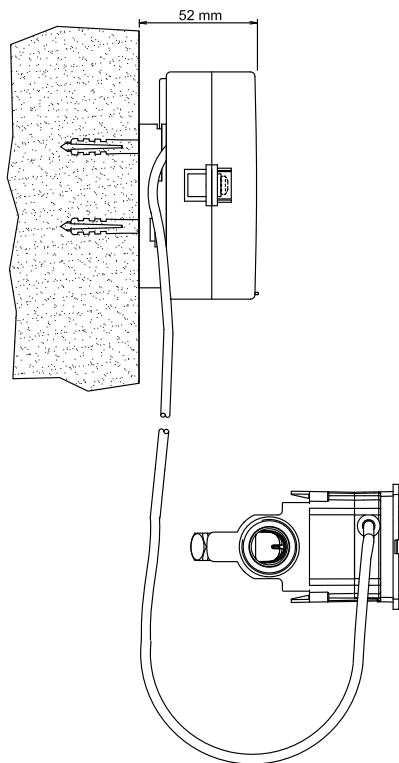

Wall mounting of MULTICAL® 62

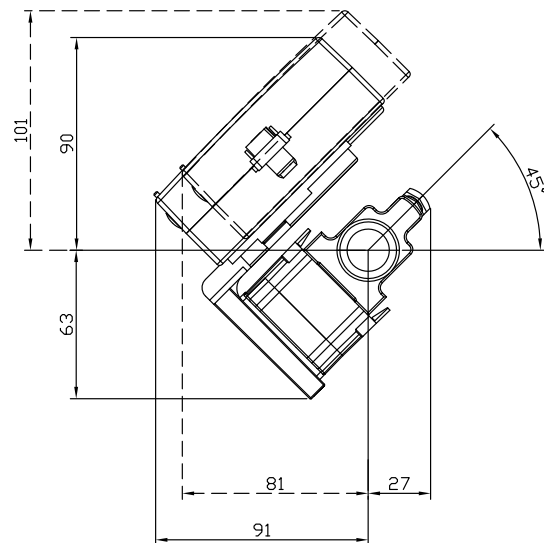

MULTICAL® 62 mounted on ULTRAFLOW® 24 with angle fitting 3026-252

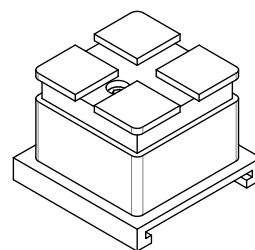

Socket extender 65-61-332

Kamstrup A/S

Industrivej 28, Stilling
 DK-8660 Skanderborg
 T: +45 89 93 10 00
 F: +45 89 93 10 01
 info@kamstrup.com
 kamstrup.com